



Caring for your vinyl patio doors will save time and money. It is necessary to take some time every year to clean and inspect your vinyl patio doors for cracks and damage. Proper maintenance requires periodic tasks to maintain long life, smooth operation, and warranty coverage. Regular inspections and minor maintenance are the best ways to keep these products in good condition.

**CONTACT US**

For questions, feel free to contact us by phone or web:

- Phone: 1-800-253-3900
- Web: www.odl.com

ODL offers a limited 10 year warranty, one year labor. Please visit us on the web at www.odl.com for complete warranty or product information.

Do-It-Yourself

Technician



**INTRODUCTION**

This guide provides important information that will help to keep vinyl patio doors looking beautiful and operating smoothly for many years. Vinyl products contain ultraviolet (UV) inhibitors designed to reduce sun damage. Vinyl is manufactured to be low maintenance and long lasting without the need for painting or finishing.

**TABLE OF CONTENTS**

Precautions and Safety . . . . . 2  
 Needed Materials & Tools . . . . . 2  
 Basic Inspections & Maintenance . . . . . 2  
 Cleaning Glass . . . . . 3  
 Vinyl Surfaces . . . . . 4  
 Hardware Cleaning & Lubrication . . . . . 4  
 Glossary . . . . . 5  
 Inspection Checklist . . . . . 6

**PATIO DOOR PARTS**

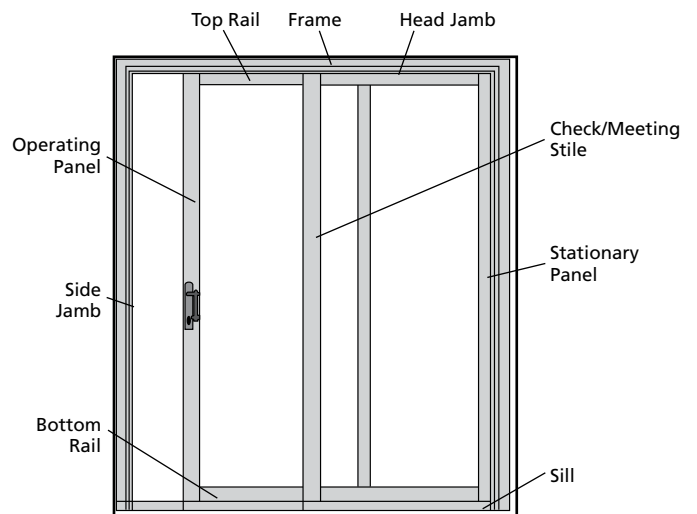

The advice offered herein can be done by a homeowner with some mechanical aptitude. If you are unsure, it is recommended that you hire a trained service provider such as a competent and licensed construction contractor or building professional. ODL disclaims any and all liability associated with the use and/or provision of these instructions. Any reliance upon the information or advice is at the risk of the party so relying. The information contained herein may be changed from time to time without notification.

## PRECAUTIONS, SAFETY & CLEANING RECOMMENDATIONS

### PRECAUTIONS & SAFETY

- Never mix cleaners and solvents. This may be dangerous as well as ineffective.
- Use help when working with a large patio door panel to avoid injury.
- Use proper/safe equipment and precautions when cleaning and servicing the exterior side of patio doors above ground level.
- If using commercial cleaning or finishing products or solvents, carefully read and follow safety instructions, warnings, cautions and disposal instructions on manufacturer's labels. Wear appropriate safety gear (e.g. clothing, goggles, gloves) and provide plenty of ventilation.
- Immediately clean spills.
- Most solvents are flammable and/or toxic and must be handled with extreme care. Do not use near open flame, sparks, or electrical motors.

### RECOMMENDATIONS

- Do not power-wash patio doors or use a garden hose; this can cause seal failure and allow water to enter the structure.
- Avoid using metal tools, razor blades, or other sharp objects and abrasive cleaners. They can damage surfaces, scratch glass and remove exterior glass coatings.
- Aggressive cleaners or solvents can damage vinyl surfaces and may cause yellowing. Immediately rinse and dry.
- Do not allow cleaners to puddle or collect at glass edges near glazing materials.
- Avoid cleaning in direct sunlight or in temperatures too hot or too cold.
- Avoid excessive rubbing and over-cleaning.
- Do not scour.
- Clean and rinse one area at a time.
- Clean twice a year (monthly in coastal areas) or when dirty.
- After-market tints and films are not recommended, as they may cause damage to the glass and/or sealant.

## NEEDED MATERIALS & TOOLS

- Baby shampoo or mild soap and water or vinegar and water
- Several clean, soft, non-abrasive, absorbent Chamois or lint-free dry cloths
- Soft bristle brush
- Spray bottle
- Vacuum cleaner
- Sponge
- Appropriate solvent (for hardware only)
- Commercial glass cleaning products or solvents (for stubborn stains)
- Plastic putty knife (for paint or label removal)
- Plastic wrap (for label removal)
- Spray silicone

## BASIC INSPECTIONS & MAINTENANCE

### WEATHERSTRIP

Inspecting and maintaining weatherstrip can help avoid costly structural damage from water leakage and energy loss due to air and/or water infiltration. Replace weatherstrip that is missing, torn, cracked, brittle, discolored, gummy, or that has no "bounce back" when pressed down. Call us for replacement instructions.

#### Precautions

- We recommend denatured alcohol for non water-soluble cleaning. Lacquer thinner may be used in small amounts, but only as directed. Thoroughly rinse any vinyl surfaces that come into contact with lacquer thinner. Other solvents such as mineral spirits or petroleum-based products may damage or dissolve weatherstrip.
- When using alcohol, always test small area first to avoid product damage.
- Do not use anything sharp near weatherstrip.

#### Light Cleaning

1. Clean with damp cloth or mild soap and water.
2. Rinse and dry thoroughly.
3. Repeat if necessary.

#### Non Water-Soluble Cleaning

Clean with denatured alcohol on soft cloth. If denatured alcohol doesn't work:

1. Clean with small amount lacquer thinner on soft cloth.
2. Repeat if necessary.
3. Clean with mild soap and water, then rinse. If unsuccessful, consider replacing weatherstrip.

#### Repair

If weatherstrip is loose or falling out of the kerf:

1. Carefully remove weatherstrip.
2. Apply thin bead of silicone sealant into kerf.
3. Reinstall weatherstrip.
4. Hold in place with tape for 24 hours.
5. Carefully remove tape.

## BASIC INSPECTIONS & MAINTENANCE – CONTINUED

### PANEL INSPECTION

Inspect patio door panel annually (monthly for coastal areas).

- Inspect stiles and rails for damage (cracks or splits in vinyl surfaces).
- Check glass for cracks. If cracked, call your local glass supplier for replacement.
- For insulating glass units, look for moisture or fogging between glass panes (most likely to occur on cold mornings). This may be an indication of seal failure. Call us for recommendations.

### GUTTERS & OVERHANGS

Gutters and overhangs protect patio doors from excess water exposure. Clear at least once per year.

### WEEP SYSTEM

Vinyl patio doors are not subject to moisture damage; however, damage could develop in the structure around the unit if water does not drain properly from the sill area to the exterior. Interior weep holes are usually a rectangular or round hole cut in the vinyl in the bottom of the sill track or in the face of a vertical member of the sill near the bottom. Exterior weep holes are usually a round or rectangular hole cut in the exterior face of the vinyl sill. These may have a small flap or baffle covering the hole.

Weep holes may be covered by a sill insert or roller track. Access to these weep holes may require removal of the panel and then removal of the snapped in sill insert or roller track.

1. Regularly clean sill track with vacuum or wipe thoroughly with damp cloth. Thoroughly remove any blockage in the corners and from the exterior weep holes caused by caulking, masonry or stucco products or a piece of trim.
2. Pour small amount of water (1 cup) into interior sill track. If water does not drain quickly from the sill through the weep system, insert a thin wire into weep hole to clear the blockage. When clearing exterior weep holes, the passages through the frame may be slightly offset to the left or right. Do not insert the wire farther than necessary because the insulating glass unit may be damaged. Call us if unsure. Repeat until water runs clear to the exterior. If not successful, call a service technician.

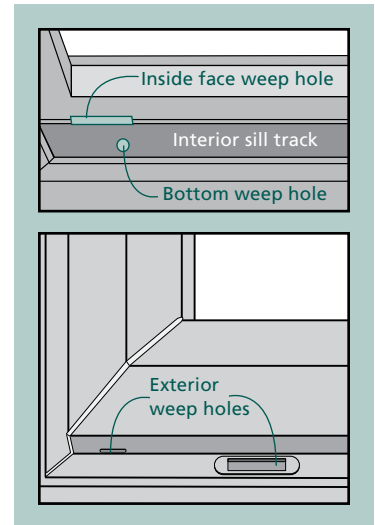

## CLEANING GLASS SURFACES

### GENERAL CLEANING

Prepare cleaning solution (1 tsp baby shampoo to one gallon of water or 1-1/2 cups vinegar to one gallon of water).

1. Rinse surface with clean water from top to bottom.
2. Clean with mild soap and water and sponge or soft brush with uniform pressure horizontally, then vertically.

**Note! Quickly rinse and dry any run-down. Don't allow cleaning solutions to collect or puddle on vinyl surfaces, crevices, etc.**

3. Promptly rinse thoroughly with clean water (sponging while rinsing may be helpful; do not allow cleaning solution to dry on the glass or vinyl surface).
4. Wipe dry with lint-free, dry cloth.
5. If necessary, repeat steps above until clean.
6. Dry window frame and sill with separate cloth.

### PAINT REMOVAL

1. Soak dried latex paint drips with warm water and baby shampoo solution.
  2. Wipe with damp cloth or sponge.
- If needed,
3. Scrape gently with plastic putty knife. Repeat soak and scrape.
  4. Repeat if necessary.

**Note! For oil-based paint drips, consult local paint professional.**

### LABEL REMOVAL

Slowly peel from one corner. If label tears or sticks, moisten with soapy water and gently scrape with plastic putty knife. Stubborn labels can be soaked with soapy water and covered overnight with plastic wrap. Gently remove with plastic putty knife.

### STUBBORN STAIN REMOVAL

For stubborn stains, commercial glass cleaning products may be necessary.

- Apply small amount directly to the stain. Avoid spilling or dripping down the glass.
- Some persistent stains may need higher strength cleaning solutions that contain active ingredient chemicals such as toluene, xylene, mineral spirits or naphtha. Special care must be taken when using these types of cleaners. Avoid getting onto vinyl surfaces.
- For oil and grease, try baking soda and water or washing soda and water.
- Rinse thoroughly with clean water and dry.

### MORE INFORMATION ON GLASS CLEANING

- The Glass Association of North America (GANA): [www.glasswebsite.com](http://www.glasswebsite.com)

**Note on Websites! Website content is subject to change and should be used for informational purposes only. ODL is not responsible for third-party information.**

## CLEANING VINYL SURFACES

Prepare cleaning solution (1 tsp baby shampoo to one gallon of water or 1 1/2 cups vinegar to one gallon of water).

1. Rinse surface with clean water from top to bottom.
2. Clean with mild soap and water and sponge or soft brush with uniform pressure horizontally, then vertically.

**Note! Quickly rinse and dry any run-down. Don't allow cleaning solutions to collect or puddle on vinyl surfaces, crevices, etc.**

3. Promptly rinse thoroughly with clean water (sponging while rinsing may be helpful; do not allow cleaning solution to dry on the glass or vinyl surface).
4. Wipe dry with lint-free, dry cloth.
5. If necessary, repeat steps above until clean.

## HARDWARE CLEANING & LUBRICATION

Cleaning and lubrication help to maintain and restore smooth operation to movable parts of patio doors and, in most cases, offer corrosion protection. Always thoroughly clean hardware before lubricating.

Maintain hardware any time doors are not opening or closing properly or at least biannually (monthly for coastal areas) for the following:

- Clean dirt/debris
- Tighten loose screws
- Replace damaged hardware

Use caution with silicone-based sprays. Apply only in small amounts and do not overspray. Wipe off excess lubricant to avoid staining and/or damage to other patio door parts. Silicone may cause some hard plastic parts to become brittle.

### HARDWARE TYPES

**Metal hardware** offers functionality, aesthetic appeal and resistance to corrosion but is not totally corrosion proof. Replace corroded hardware.

**Plastic hardware** offers high resistance to the elements; however, over time, can deteriorate from ultraviolet light, heat, cold, and chemical exposure.

### PRECAUTIONS

The following substances may damage protective hardware finishes. Do not use:

- Vinegar-based cleaners
- Citrus-based cleaners (lemon, etc.)
- Paint removers
- Window cleaners
- Brick/siding washes
- Any other industrial or abrasive cleaners

## HARDWARE CLEANING

### GENERAL CLEANING

1. Remove hardware for easier cleaning.
2. Use mild soap and water on a soft cloth or sponge; rinse and wipe dry.

**Note! For stubborn dirt, use a soft bristle brush to gently scrub.**

3. Apply several coats of high quality, non-abrasive car wax.
4. Reinstall hardware.

### HEAVY CLEANING

Solvents, abrasives, and other cleaners could cause damage to protective coatings on hardware. If the general cleaning procedure is not sufficient, call us for recommendations.

## HARDWARE LUBRICATION

Different hardware parts need different types of lubricants.

Suggested Lubricant Types
<p><b>White or Lithium Grease:</b> Protects metal surfaces against corrosion, reduces friction and wear on moving parts, and is an excellent multi-purpose lubricant.</p>
<p><b>Light Oil (such as 3-in-One®):</b> Use for sliding or rotating joints.</p>
<p><b>Spray Silicone:</b> Use for slider tracks, jamb liners, and weatherstrip. <b>Note!</b> Do not spray directly onto hardware surfaces. Spray onto clean cloth to apply.</p>

## PLASTIC HARDWARE

Most hard plastic hardware parts require periodic cleaning for smooth operation and do not require lubrication.

## SLIDER TRACKS

Slider tracks can become dirty and difficult to operate. Clean and lubricate as follows:

1. Vacuum track or wipe with a soft cloth.
2. Apply spray silicone to dry, soft cloth. Wipe onto track, and/or weatherstrip. Do not apply silicone to pile (fuzzy) weatherstrip.

## HARDWARE LUBRICATION – CONTINUED

### PATIO DOOR ROLLERS & MULTI-POINT LOCKS

Removing patio door panels can be dangerous and should be performed by service personnel or at least with additional help.

1. Remove door panel.
2. Tip door panel for access to rollers on the bottom.
3. Lubricate rollers where the shaft goes through the middle of the wheels with light oil.
4. Lightly oil multi-point lock at each latch point.
5. Spray keyway lock with graphite lubricant.

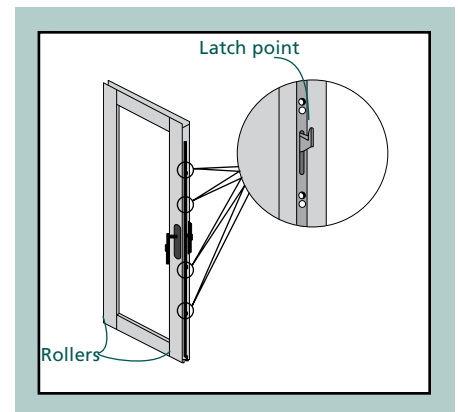

## GLOSSARY

### Frame

The assembly of structural members used to fasten the patio door to the structure.

### Insulated Glass Unit

A sealed assembly of two or more panes of glass separated by a spacer.

### Kerf

A groove that often holds weatherstrip.

### Patio Door Panel

An assembly comprised of stiles (vertical pieces), rails (horizontal pieces) and the patio door's glass.

### Rail

The horizontal piece of a panel.

### Seal Failure

The airtight seal between two panes of an insulating glass unit has broken and is usually discovered when excess moisture fogs the inside of the glass panes.

### Side Jamb

The vertical frame member on the patio door.

### Sill Track

The track on the sill of a patio door that guides the panel as it opens and closes.

### Stile

The vertical piece of a panel.

### Weatherstrip

A strip of material that covers the joint between two separate parts of a patio door and is used to prevent rain, snow and cold air from entering.

**INSPECTION CHECKLIST**

INSPECTION DATE \_\_\_\_ / \_\_\_\_ / \_\_\_\_

EXTERIOR	NOTES
<ul style="list-style-type: none"> <li>• Vinyl Surface                             <ul style="list-style-type: none"> <li><input type="checkbox"/> Dirty</li> <li><input type="checkbox"/> Cracks, scratches, blisters, other damage</li> </ul> </li> </ul>	
<ul style="list-style-type: none"> <li>• Sealant Joint                             <ul style="list-style-type: none"> <li><input type="checkbox"/> Cracks, voids, other damage</li> <li><input type="checkbox"/> Deterioration, loss of adhesion</li> </ul> </li> </ul>	
<ul style="list-style-type: none"> <li>• Glass                             <ul style="list-style-type: none"> <li><input type="checkbox"/> Dirty</li> <li><input type="checkbox"/> Scratched, cracked, other damage</li> </ul> </li> </ul>	
<ul style="list-style-type: none"> <li>• Weatherstrip                             <ul style="list-style-type: none"> <li><input type="checkbox"/> Missing or loose</li> <li><input type="checkbox"/> Tears, cracks, other damage</li> <li><input type="checkbox"/> Brittle, gummy, discolored</li> <li><input type="checkbox"/> No "bounce back"</li> </ul> </li> </ul>	
<ul style="list-style-type: none"> <li>• Gutters                             <ul style="list-style-type: none"> <li><input type="checkbox"/> Dirty</li> <li><input type="checkbox"/> Damaged</li> <li><input type="checkbox"/> Missing</li> </ul> </li> </ul>	
INTERIOR	NOTES
<ul style="list-style-type: none"> <li>• Vinyl Surface                             <ul style="list-style-type: none"> <li><input type="checkbox"/> Dirty</li> <li><input type="checkbox"/> Scratched, cracked, other damage</li> </ul> </li> </ul>	
<ul style="list-style-type: none"> <li>• Glass                             <ul style="list-style-type: none"> <li><input type="checkbox"/> Dirty</li> <li><input type="checkbox"/> Moisture between Panes (insulating glass only)</li> </ul> </li> </ul>	
<ul style="list-style-type: none"> <li>• All Product Hardware                             <ul style="list-style-type: none"> <li><input type="checkbox"/> Dirty or damaged</li> <li><input type="checkbox"/> Discolored or tarnished</li> <li><input type="checkbox"/> Problems with sash locks</li> </ul> </li> </ul>	
<ul style="list-style-type: none"> <li>• Patio doors                             <ul style="list-style-type: none"> <li><input type="checkbox"/> Track dirty</li> <li><input type="checkbox"/> Problems with rollers</li> <li><input type="checkbox"/> Problems with locks</li> <li><input type="checkbox"/> Locks need lubrication</li> </ul> </li> </ul>	